

HENGSTLER

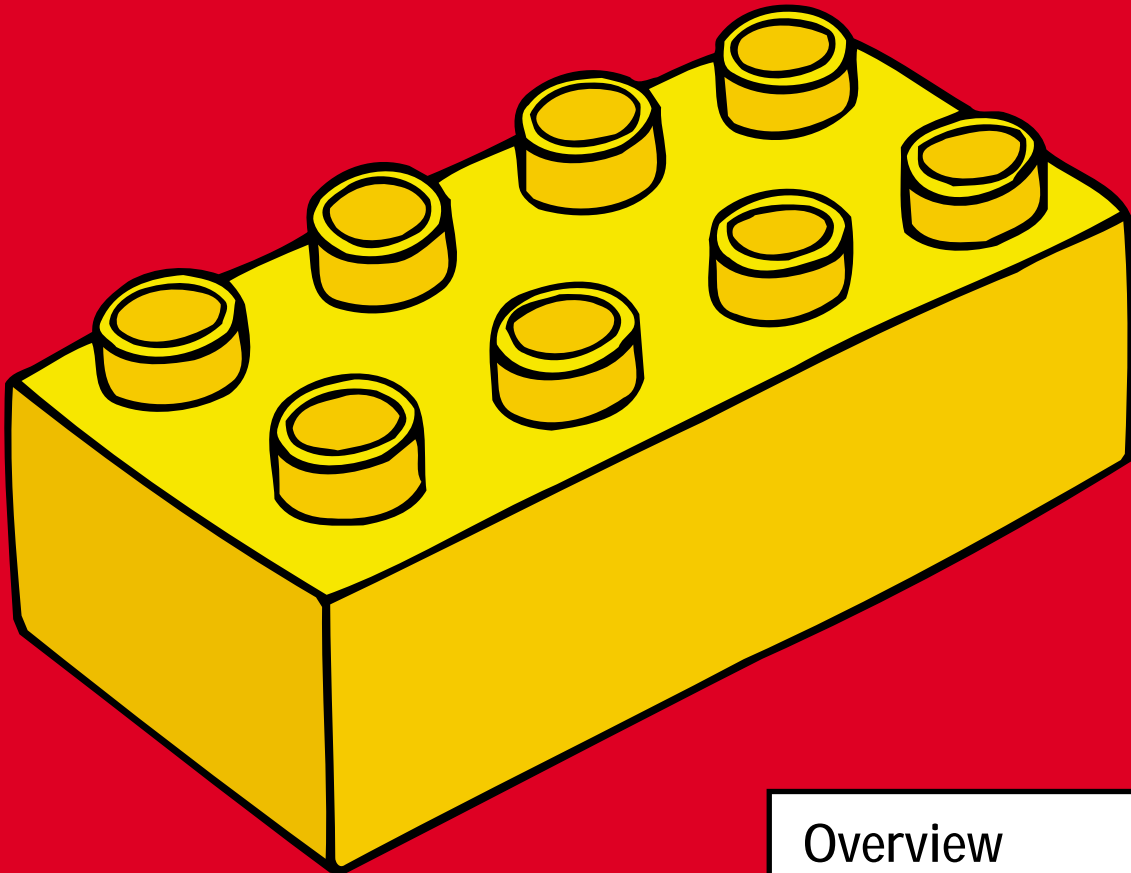

Overview Product Range Components

for:

- Counting
- Control
- Indication
- Measurement
- Switching
- Printing

Innovative products from your
competent partner. Worldwide.

IBH ELEKTROTECHNIK GMBH
Postfach 12 06 • 20001 Neumünster
Güldenbügel 10 • 20001 Neumünster

IBH 

Hamburg

Düsseldorf

Frankfurt

München

Wien

Zürich

IBH 

Düsseldorf

Frankfurt

München

Wien

Zürich

IBH 

01 43 22 21 21-22

01 43 22 21 21-20

01 43 22 21 21-11

01 43 22 21 21-10

01 43 22 21 21-09

01 43 22 21 21-08

01 43 22 21 21-07

01 43 22 21 21-06

01 43 22 21 21-05

01 43 22 21 21-04

01 43 22 21 21-03

01 43 22 21 21-02

01 43 22 21 21-01

01 43 22 21 21-00



Contents

Counters	Page 4
■ Totalizing, preset and multi-function counters	
■ Counters with interface	
■ Measuring systems	
Elapsed Time Meters, Timers, Pneumatic Components	Page 5
Tachometers, Position Indicators	Page 6
Controllers "grado"	Page 7
Encoders	
■ Incremental encoders	Page 8
■ Absolute encoders	Page 9
■ Hollow shaft / stainless steel encoders	Page 10
■ Motor / sinewave encoders	Page 11
Linear and Angle Measurement Systems	Page 12
Relay Technology	Page 14
■ Safety relays	Page 15
■ Bistable relays	Page 16
■ Mains separation, high-voltage relays	Page 17
Printers / Cutters	Page 18
Service Page	Page 20
Fax Form + Further Hengstler Products	Page 22

Better by Competence

This brochure presents our comprehensive product range, which is characterized (as are all Hengstler products) by state-of-the-art technology, excellent design and highest standards of quality and reliability.

Hengstler – you can count on us.



Customer Orientation

- Hengstler is never far away - wherever you are in the world
- Application-specific assistance
- Customer-oriented manufacturing (one-piece-flow)
- Fair price/performance ratio
- Short delivery times and a high degree of availability
- 48-hour repair service

Experience

- Hengstler was founded in 1846 and has been manufacturing: counters: since 1926, printers: since 1970, sensors: since 1987, relays: since 1983...

Competence

- Vast know-how in the fields of development, manufacturing and sales marketing
- Assistance and support are provided by specialists.

Quality

- High-quality materials in accordance with VDE (Association of German Electrotechnical Engineers)
- UL, CL- and TUV approvals
- DQS-certified to ISO 9001

Variety

- Hengstler offers a wide range of components for counting, controlling, indicating, measuring, switching and printing
- Get it all from one source!
- Benefit from numerous variants - for added flexibility.

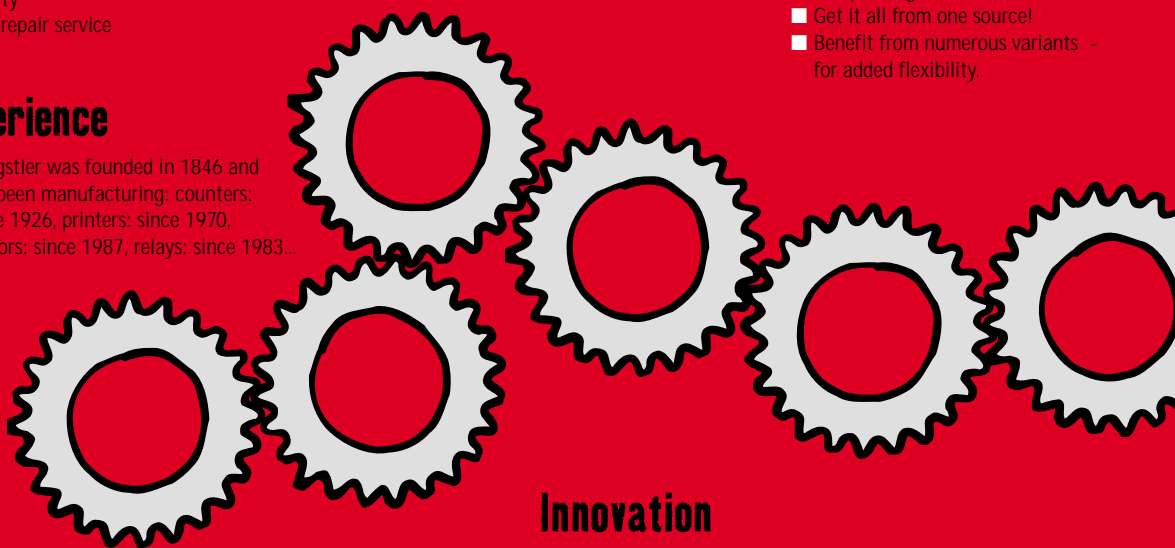

Innovation

- Product development is based on state-of-the-art technology and highly advanced processes.
- Our products are setting the pace - around the globe
- We offer communicative products with state-of-the-art bus technology.

Successful with Hengstler

Innovation at an international level

Our numerous branches and representatives in Europe, America and Asia have made us a truly international enterprise. Our availability around the globe is, of course, a great benefit for our customers - the next Hengstler contact is never far away.

Our sound footing in all parts of the world also has a positive effect on our product know-how. Findings from worldwide research programs provide a pool of information from which, in turn, the material for the carefully directed, overall technological concept is won. These findings form the practice-oriented basis for ongoing innovation and efficiency in all corporate sectors.

The pace of innovation is getting faster and faster in all sectors of technology. Only those who are able to follow or even set this pace will continue to be competitive. Strong, reliable partners are needed to help you cope with these new demands. You need partners whose top priority is added product value/customer value, customer-orientation and high quality.

And taking all this into account, Hengstler is your partner of choice.

Hengstler is a leading European manufacturer in the field of industrial counting and control components, e.g. counters, encoders, industrial and temperature controllers, as well as relays.

Hengstler's product range is completed by printers and cutters, with Hengstler being the biggest manufacturer in Europe.

Hengstler: Your Technology Partner

One of our particular strengths is the project management of custom applications. The basis for this is our wide experience gained over many years in the fields of electromechanics, mechanics, pneumatics and electronics which is, of course, mirrored in our product program. Hengstler offers its customers complete support starting at the project planning and development stage right through to the final product. At present we are handling complex projects in the field of pneumatics and printers for well-known companies, such as Bosch, Festo, IBM and Siemens.

Talk to Hengstler.
We can offer solutions.

IBH ELEKTROTECHNIK GMBH
Postfach 32 09, 22825 Norderstedt
Gutenbergring 35, 22848 Norderstedt



Hamburg
Osnabrück
Rendsburg

Elektronik (0 40) 52 30 52 21-22
Elektromechanik (0 40) 52 30 52 26
Zentrale (0 40) 52 30 52-0
Telefax (0 40) 52 88 21 63
e-Mail info@IBH-Elektrotechnik.de

Totalising, Preset and Multifunction Counters ...

- Electronic
- Electromechanical
- Mechanical
- Pneumatic



The "tico" product family:
flexible and user-friendly

Possible applications for this versatile and varied counter range are practically unlimited. Typical examples are e.g. event counting, totalizing, usage calculation, machine life and maintenance counting, length measuring, decentralised counting for PLC and PC applications, dosage and filling, production process control with batch counter, etc. Our product range will meet your requirements whether you are looking for **electronic, electromechanical, mechanical or pneumatic** counters.

Totalizing Counters

... are mainly used to log a series of events and display the total as a number. We have them in a whole range of sizes from mini-counters to the building-block-system, with its basic grid of 25 x 50 mm or in DIN sizes, and offering such a wealth of functions, benefits and designs that we are sure to be able to meet your needs.

Preset Counters

... are counting devices with control functions. With many different versions available, the range of possible applications is very wide. Most electronic preset counters offer 2 presets, in order to control rapid or slow positioning or rough or fine dosage by means of a trail signal.

Counters with Interface

... are totalizing or preset counters that can handle more complex automation functions and are able to communicate with other systems such as PC, PLC or host and output systems such as printers or indicators via a normed fieldbus interface, e.g. Profibus.

Multi-Function Counters

... offer a wide range of basic functions such as counter, tachometer, time counter, shift counter, or batch counter. Due to their unique functions and their customer-programmable parameters, you can very easily adapt all these devices to your own individual requirements.

Systems

... measuring systems are tailor-made solutions for various applications such as length measurement and piece counting. High-quality Hengstler components such as counters, printers and encoders are designed to work well with each other, guaranteeing ease of installation and security of operation.



IBH ELEKTROTECHNIK GMBH
Postfach 32 09, 22825 Norderstedt
Gutenbergring 35, 22848 Norderstedt



Hamburg	Elektronik	(0 40) 52 30 52 21-22
Osnabrück	Elektromechanik	(0 40) 52 30 52 26
Rendsburg	Zentrale	(0 40) 52 30 52-0
IBH	Telefax	(0 40) 52 88 21 63
	e-Mail	info@IBH-Elektrotechnik.de



Keep Track on Operating Hours

Time and Run-Time Counters

Time counters show how long machinery or equipment has been switched on for. They show elapsed warranty times, usage duration and can indicate whether it is time to carry out routine maintenance work. We can offer you our time preset counters wherever control needs to be time-based and our powerful miniature time counters are particularly popular in machine construction and heating system designs.



Flexible and Economical Timer Family

With our electronic multi-function time relays, we cover the complete spectrum from low-cost to high performance digital, in a wide range of applications. Users can get it all from a single source: economic and also special solutions for all their timing tasks.

The **742 timer family** sets new standards in terms of multi-functionality, flexibility and sheer value for money. Tico 742 is the only product on the market which combines so many operations in one unit by offering two separate, 4-digit timer preset options, batch counting, %-setting, cumulative counting and edge-triggered line transients.

Pneumatic Control

If you prefer to drive your equipment with air, we can offer you a range of high-quality pneumatic components to control, convert, count and display.

- Totalizing counter to count events, pieces and batches, to display program steps, etc.
- Preset counter with pneumatic output signal, also for dosage operations, quantity and piece control, etc.
- Preset time counter
- Timers (DIN 24 x 48 mm)
- Proximity switch (fully pneumatic)
- Signal indicator for the pressure display in plastic tubes





Production Processes - Under your Control

Rate Meter and Flow Display

Rate meters are used to track events which occur in a particular order. The principle remains the same whether we are talking about speed, rotations or volume throughput; only the parameters and the dimensions change.

Advantages offered include:

- particularly wide frequency range
- freely programmable limiting values
- Prescaler
- DIN dimensions
- Digital or analogue inputs
- Production logging

plus additional options all add up to produce a tachometer which is simple to operate but with universal application.

Position Indicators

By using position indicators you can determine an object's position by processing its corresponding angle and travel co-ordinates. Typical applications are the display of feed-in values, lengths, machine positions as well as totals.

Special Advantages

- Large easy-to-read display
- Simple programming
- Limiting values prescaler
- Prescaler
- DIN dimensions
- Ease of operation



IBH ELEKTROTECHNIK GMBH
Postfach 32 09, 22825 Norderstedt
Gutenbergring 35, 22848 Norderstedt



Hamburg
Osenebrück
Rendsburg
IBH
ELEKTROTECHNIK GMBH

Elektronik (0 40) 52 30 52 21-22
Elektromechanik (0 40) 52 30 52 26
Zentrale (0 40) 52 30 52-0
Telefax (0 40) 52 88 21 63
e-Mail info@IBH-Elektrotechnik.de



*Multi-channel controller system:
Ideally suited for DIN C rail mounting in
control cabinets*

Flexible and Economical – Industrial Controllers and Indicators

The Variety of "grado" Products

- Industrial controllers
- RaPID industrial controllers
- Temperature controllers
- Open-loop valve-motor-drive controllers
- Limit controllers
- Program controllers
- Multi-channel controller system with bus connection

What Makes These Controllers Special?

- Simplest operation
- Newest technology
- High flexibility
- Safety through self-optimization
- Low prices and short delivery times
- Compact DIN size and attractive design

Control parameters can be adapted very easily for the "grado" through the auto-tuning function. By using the pre-tune feature, the process is brought up to preset values during power-on, with no overshoot. After that, automatic self-tuning takes over

control of parameter monitoring, during run-time. All devices can be easily programmed from your PC using the interface. For the multi-channel controller the system width is very compact and identical with the number of modules used. This system makes it possible to draw back from the PLC, with subsequently lower cost for parametrization, programming and control, but in addition with considerably higher values for performance and accuracy.



Application Examples

- Heat treatment and environmental simulation
- Food and drink industry
- Glass industry
- Paper production
- Power supply
- Climate technology
- Chemicals and pharmaceuticals
- Semi-conductor industry
- Rubber processing
- Building and ceramic materials
- Automotive sector
- Packaging machines
- Furnace and drying processes
- Bakery equipment



Encoder Variety at its Best: Incremental Encoders

User Advantages

- Your encoder version when you want it
- Error elimination and increased safety with OptoAsic
- Long-term accuracy through the use of laser adjustment instead of potentiometers
- Outputs protected against short circuits and overload, over the complete temperature range
- Self-monitoring and error identification
- High EMC safety

Incremental encoders are used for angle and linear measurement as well as for positioning and they are often combined with mechanical gearing such as rack-and-pinion measuring wheels and ball screws. Each positional step produces one impulse.

Our Program Range Incremental Encoders

- Industrial types, also explosion-proof
- Hollow shaft
- Economy types

Technology and Flexibility

Up to 50 individual components are replaced by a single, monolithic, integrated OptoAsic. Through our specially developed modular system, we can offer you over 1 million different encoder versions from just 4 component classes.

The Modular System lets you Choose:

- Flange and shaft in different connection dimensions and diameters from 30 to 76 mm
- Resolution between 1 and 10,000 impulses giving up to 40,000 measurement steps
- Output drivers for cables up to 200 metres long
- Covers, cables and plugs in all lengths and designs
- Protection class up to IP 67

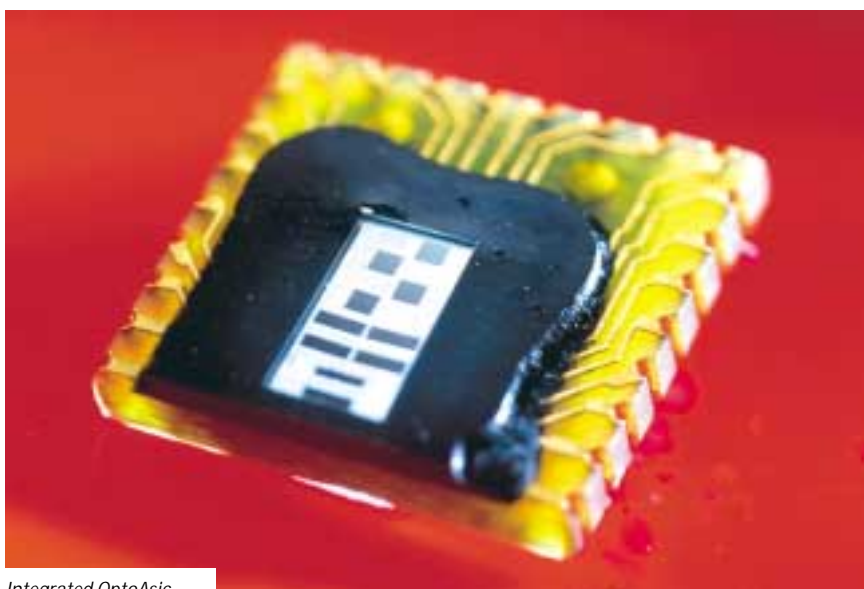

Integrated OptoAsic

Examples for Typical Applications of Incremental Encoders

- Franking machines
- Train door closing systems
- Table robots
- Lens grinding
- Plotters
- Optical fibre testing
- Spreading machines
- Printing
- UV-welding
- Label machines
- X/Y displays
- Analysis equipment
- Drilling equipment
- Mixing

DeviceNet.



Technically Brilliant Absolute Encoders

Application Examples

- Gantry robots
- Fan covers
- Winding machines
- Conveyor systems
- Cam controllers
- Plastic injection moulding
- Packaging machines
- Extruders
- Folding machines
- Printing
- High-bay racking
- Presses
- Wind power stations

Absolute Encoders

... as well as measuring angle positions, they also measure linear movement which is converted into rotational movement, as for example with a toothed drive, a pinion drive or a spindle.

The special feature of absolute encoders is that a unique digitally coded signal can be assigned to each individual measurement step. Encoder versions with 10 to 14 Bit single-turn and multi-turn variants (26 Bit) are available. An important application safety aspect is that the multi-turn version has gearing elements. The productivity benefit is that you do not have to provide a reference point with absolute encoders as you do with incremental encoders.

Hengstler absolute encoders are all equipped with monolithic, integrated optoelectronics (OptoAsic), reliably replacing up to 200 individual components.

Highlight Features

- High functional safety through variance scanning in Gray code
- High electromagnetic compatibility with up to 4 kV on the connection cable and 20 kV electrostatic discharge
- Long service life
- High flexibility through modular system
- Stainless steel encoder versions for off-shore or food industry applications
- Hollow shaft versions (10 or 12 mm diameter) with shorter mounting length and easier fitting

State-of-the-art Interface Technology

- Tristate-Parallel driver
- Interbus K2/K3
- Interbus Loop
- SSI
- Profibus DP
- CAN; CANopen
- DeviceNet
- SUCOnet



Twofold flange connectors

Hollow shaft Encoders / Stainless Steel Encoders

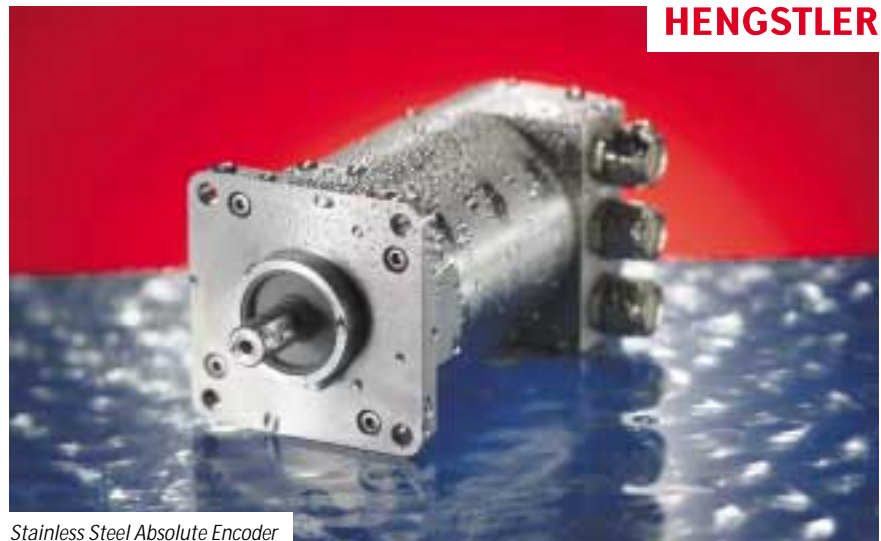

Stainless Steel Absolute Encoder

Versions available according to explosion protection class II to EEX d IIC T4/T6



Hollow Shaft Encoders

Due to the broad variety of versions available and their special performance, our incremental and absolute encoders with hollow shaft are suited for all kinds of applications. The range comprises encoders with clamping shaft and only 36 mm exterior diameter as well as encoders with diameter 76 mm and through hollow shaft, with shaft diameters from 15 to 42 mm. These versions are fitted with a stator coupling and can be mounted directly on the shaft. Further versions are available with full shaft or hollow shaft open at one side. Resolutions range from 1 to 10,000 impulses.

Advantages for all Versions:

- High reliability
- Long service life
- Low mounting depth
- Easy mounting

Stainless Steel Encoders

Thanks to their high degree of protection our stainless steel encoders are ideally suited for applications with special requirements regarding hygiene or corrosion resistance, e.g. packaging machinery in the food industry, ship equipment, (e.g. cranes, winches, cable laying ships), offshore applications. Available as single turn or multi turn encoder and with all the usual field bus interfaces. Connection is by radial cable or removable bus connector with the field bus versions.



Hollow Shaft Encoder RI 76



Hollow Shaft Encoder RI 36-H





Precise, robust, non-contact:
the innovative way to measure length and angles

Worldwide, Hengstler is one of the leading encoder manufacturers

■ The systems described here combine the accuracy of optical encoders with the ruggedness of magnetic systems. Truly an innovative and unique concept - worldwide.

Speed and precision

With the high speed and maximum resolution offered by the inductive linear and angle measurement systems from Hengstler, you have the optimum solution for all industrial applications which call for precise linear or axial positioning.

Wide variety of applications

Due to its extreme ruggedness and low susceptibility to contamination, these systems are extremely well suited for the monitoring of machines and equipment under many different operating conditions.

High resolution values

High precision sine and cosine signals allow up to 1024-fold interpolation delivering resolutions right down to 0.25 µm. Optionally, integrated interpolation electronics create RS422 signals with a resolution of 5 µm. In this way, the systems are compatible with all servo drivers with sine 1 V_{pp} or RS422 encoder inputs.

- Electronics manufacturing
- Printed circuit board assembly
- Metalworking
- Woodworking
- Packaging
- Materials handling
- Punches, presses



IBH ELEKTROTECHNIK GMBH
Postfach 32 09, 22825 Norderstedt
Gutenbergring 35, 22848 Norderstedt



Elektronik	(0 40) 52 30 52 21-22
Elektromechnik	(0 40) 52 30 52 26
Zentrale	(0 40) 52 30 52-0
Telefax	(0 40) 52 88 21 63
e-Mail	info@IBH-Elektrotechnik.de

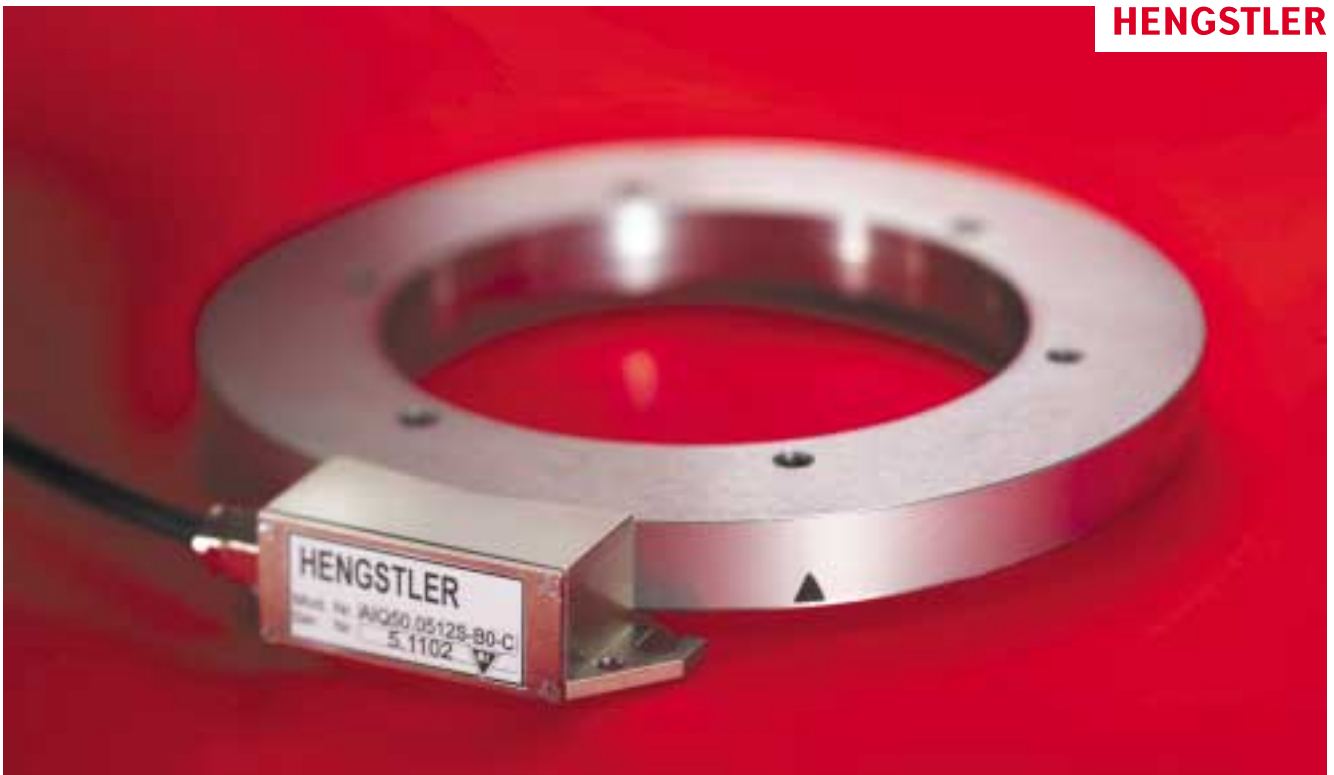

Real-time output signals

Because there is no time delay with the output signals, you can utilise the complete bandwidth of servo controls, particularly in conjunction with linear motors. The application advantages are:

- Unlimited dynamics up to linear travel speeds of 1,200 m/min or rotational speeds of 20,000 1/min
- High processing quality
- Precise contours and short idle times

Extremely robust construction

Because of the inductive function principles employed, Hengstler's linear and angle measurement systems feature contact-free and friction-free operation. They meet IP66 protection requirements and are completely impervious to extreme environmental conditions such as dust, dirt, grease, oil or water as well as mechanical stresses.

High resolution sensor technology

The measuring systems apply the principle of variable reluctance which means that the encoder uses the reluctance of the etched metal base to distort the magnetic field produced by the read head. Two sensors detect these changes which are converted to high quality sine-wave signals by the electronic circuitry. The sensors are offset and produce sine and cosine signals. A separate sensor detects variations in the gap between the read head and the scale and adjusts the circuit's gain to stabilise signal amplitude. Optional interpolation electronics convert the analogue signals to high resolution square wave signals.

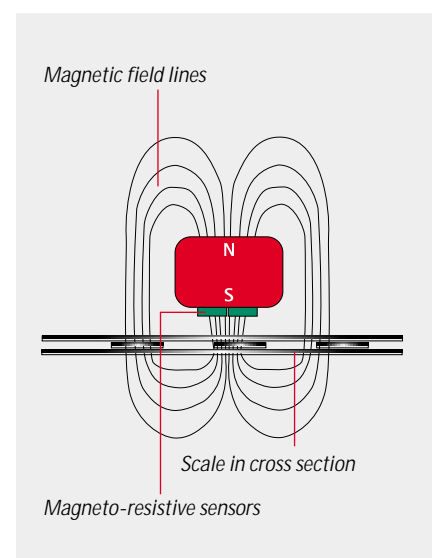



The Best in Relay Technology Our Complete Program

Since the two companies Hengstler and Kaco came together in the middle of 1996, we have been able to offer you the widest possible relay product range to meet all needs. We offer relays from 1 A to 100 A, in various designs and with the right contact material to meet all loading requirements. If you have any questions about which is the right product for you, our specialists are

available, in person or on the phone, to give you all the help you need. The use of relays is an ongoing trend. They provide a powerful, flexible and economical interface between electronics and load.

We offer the Wide, Reliable Range:

- Safety relays with force-guided contact set
 - Powerful high voltage relays
 - Mains separation relays
 - PCB relays
 - Bistable relays
 - Remanence relays
- ... and of course also customised specials.



IBH ELEKTROTECHNIK GMBH
Postfach 32 09, 22825 Norderstedt
Gutenbergring 35, 22848 Norderstedt



Hamburg
Osnabrück
Rendsburg
IBH

Elektronik (0 40) 52 30 52 21-22
Elektromechanik (0 40) 52 30 52 26
Zentrale (0 40) 52 30 52-0
Telefax (0 40) 52 88 21 63
e-Mail info@IBH-Elektrotechnik.de

Our Particular Speciality – Safety Relays



Twin Safety Relay – a world innovation

Make no compromises when it comes to safety issues for people and machines. Safety relays with force-guided contact set containing from 2 to 10 contacts give you the

safety you are looking for. They can eliminate the risk of danger to man or machine, caused by switching or system failures.

We make our safety relays as small as possible, but they are extremely big on reliability and swit-

ching safety. They are big on variety too, big enough and flexible enough to meet all your needs.

The global importance of safety relays is growing rapidly and the worldwide marketplace is a challenging place to be in. With Hengstler you have the widest range to choose from to meet your and your customers' needs.

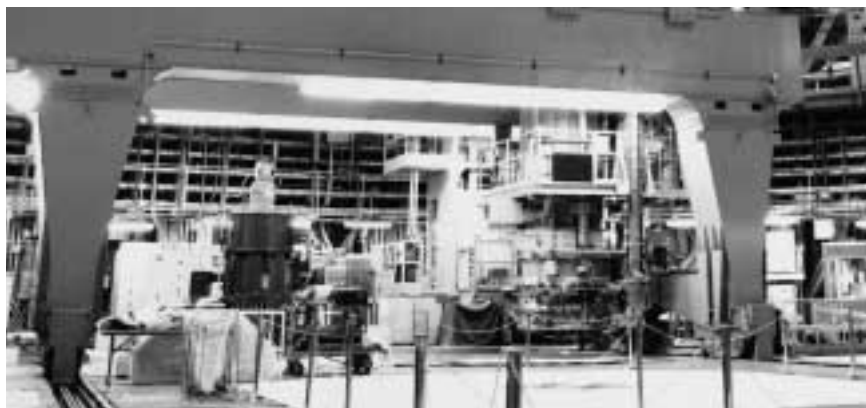
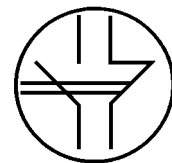

Application Examples

- Monitoring devices
- Emergency STOP modules
- Safety door control
- Two-hand control systems
- Sensor output units
- Light barriers and curtains
- Rotation control
- Down-time monitoring



Heavy-Duty Bistable Relays

Many control applications demand low power requirements which call for a high switching performance at many different load levels. These demands can be met by the bistable relays made by Hengstler-Kaco.

Characteristics of Bistable Relays:

- 1 impulse switching
- Current up to 100 A
- Excitation is retained after switch-off, until the relay is switched back to active by a corresponding negative excitation.
- Impulse duration is 20 – 30 ms so the unit does not get warm through coil heat loss
- The switching position is set by the direction of excitation. This is achieved by using permanent magnets, i.e. poled bistable relay.
- The permanent magnets allow a high, constant contact strength in both switching positions, irrespective of the power supply.

- The high contact strength at closing and opening minimises contact resistance and power heat loss in the area of the contacts
- Simplified control layout by the use of symmetrical relay control.
- Control can be made with a memory capacitor.
- Relay is vibration and shock resistant.

Application Examples

- Ripple control receiver
- Pre-payment meter (instrumentation and control in buildings)





Mains Separation Relays

Mains separation relays are primarily used where devices require a bi-polar mains separation, for instance to conform to DIN VDE 0700, with a contact opening of 3 mm. Portable electronic testing devices must always

be in secure and stable state for the operator to be able to carry out the required tests, i.e. the load circuit must be separated from the mains. The same principle applies of course in medical technology, to protect the patient.

Application Examples

- Domestic appliances
- Medical devices
- Laboratory equipment
- Measuring and test equipment

Compact High Voltage Relays

With high voltage relays you can switch up to 5,000 Veff, making them an interesting component for use in test equipment, e.g. test switching high voltage transformers or for testing conductors or insulation. Laboratories are also often places where high voltage switching tasks are carried out.



Application Examples:

- Measurement and test equipment

IBH ELEKTROTECHNIK GMBH
 Postfach 32 09, 22825 Norderstedt
 Gutenbergring 35, 22848 Norderstedt



Hamburg	Elektronik	(0 40) 52 30 52 21-22
Osnabrück	Elektromechanik	(0 40) 52 30 52 26
Rendsburg	Zentrale	(0 40) 52 30 52-0
IBH	Telefax	(0 40) 52 88 21 63
	e-Mail	info@IBH-Elektrotechnik.de



Thermal bon printer, Pixxo series

Printer System Solutions

The particular feature highlights of Hengstler printer components are high reliability, simplicity of handling - both in terms of paper and ribbons - as well as being maintenance-free.

These are convincing features offering your application maximum security and unparalleled levels of user comfort, advantages you will also appreciate with the complete printing system solutions which we offer.

You will find large numbers of Hengstler printer in use in, e.g.:

- **Receipt and Journal printers for ATM machines** (Automatic Teller Machines), since particularly high levels of reliability are an important criteria here
- **Information points.** No matter if it is a question of printing city plans and information for visitors or entrance tickets to sporting or cultural events, our high-speed thermal coupon printer stands out on account of its speed and graphic capabilities.
- **Travel ticketing machines** of all types, e.g. subways, trains and busses. Our ticket printer performs reliably whether static or on the move.

This security of ticket or receipt dispensing is guaranteed through our format and mark control systems.

Whether you use thermal or impact printers is your choice, depending on your preferences and your particular application.

A great advantage for you is the depth of our experience gained with applications covering the whole spectrum of commerce and industry, our special competence and the synergistic know-how resulting from our own wide variety of products and technologies.

Application Examples

Application Focus Printers

- ATMs
- Ticket vending machines
- Kiosk systems

Industrial/Commercial Applications

- Cash register systems
- Bar code labeling
- Measurement recording
- Monitoring systems
- Analytical equipment

Medical Applications

- Analytical equipment
- ECG printing

Traffic

- Motorcar diagnosis protocols
- Ticket issuing machines

Printer Range

- Impact ticket printer
- Thermo bon printer
- Impact bon printer
- Thermo journal printer
- Impact journal printer



Impact ticket printer, Printo series



NEW: "Linerless" cutters for cutting linerless labeling material

Innovative System Solutions plus Tailor-Made Partnerships



Cutter D, Series 685.56

Customised Cutting after Printing

After printing, there is often a requirement to cut the printout or the receipt off. Hengstler offers you a multi-width range of powerful and reliable cutters. They are maintenance-free. Competence and experience have made Hengstler the biggest paneuropean manufacturer of cutters. Hengstler cutters are widely used e.g. at petrol or gas stations. They guarantee a clean cut in all climatic conditions. Whether in Alaska or the Caribbean, our cutters' reliability can always be counted on.

Our particular strength is in customer-driven projects and applications. Based on our long and varied experience in electromechanical, mechanical, pneumatic and electronic products, we offer customers complete support

and advice from project definition, through development right up to the end-product. At present we are working on sophisticated and complex projects in the area of pneumatics and printers, e.g. for wellknown companies such as Bosch, Festo, IBM and Siemens.



Application Examples for Cutters

- Info points
- Ticketing machines
- ATMs, automatic tellers
- Cash register systems
- Label printing
- Scales, weighing machines

Your Advantages

- Hengstler Cutters Feature
- Long operation life
 - High cutting power
 - Maintenance free
 - Interior or exterior use
 - Variable cutting widths, 60 – 500 mm
 - Low power requirements

Our Top Service for You

1. Customer service

– always remains close to you – thanks to our extensive sales & distribution network. Please contact us, see rear page.

Talk to Hengstler.

Customer Advantages

- Personal customer service
- Many years of experience

We offer solutions.

2. World-wide representation

You will always find a friendly contact at Hengstler – wherever you are in the world. Our experienced, competent partners are familiar with your branch – just get in touch. Please contact us, see rear page.

Customer Advantages

- We're there for you – wherever you are – worldwide

3. Always on the safe side

Quality and reliability of our products are our top priority.

Our quality management system is DQS-certified to DIN EN ISO 9001.

Reg. No. 1540-01.

4. Delivery

Your orders are shipped on time, at the delivery dates requested by you and also as part-shipments, if required. Customer orders are always entered directly, which ensures high flexibility and short delivery times despite our wide range of different products. And – if there should be an emergency despite all careful planning – we'll be prepared to ship at once.

Customer Advantages

- Overnight
If you order a product from our main product list before 10.00 a.m., your order will be shipped on the same day.

5. Repair Service

Customer complaints

We are always there for you if there should be any problems.

Please contact us, see rear page.

Customer Advantages

- Emergency Service
- Repair/Customer Complaint Report



Our Repair Team at Hengstler

6. Technical Support

If you should have any technical questions concerning your product selection or specific application – get fast and competent help from: Tel.: +49 7424-89 539

Or by e-mail:

AnhMinh.Nguyen@hengstler.de

or claus.grimm@hengstler.de

or norbert.weber@hengstler.de

Customer Advantages

- Quick response to your technical queries.



IBH ELEKTROTECHNIK GMBH
Postfach 32 09, 22825 Norderstedt
Gutenbergring 35, 22848 Norderstedt



Hamburg
Osnabrück
Rendsburg
IBH
ELEKTROTECHNIK GMBH

Elektronik (0 40) 52 30 52 21-22
Elektromechanik (0 40) 52 30 52 26
Zentrale (0 40) 52 30 52-0
Telefax (0 40) 52 88 21 63
e-Mail info@IBH-Elektrotechnik.de

IBH ELEKTROTECHNIK GMBH
Postfach 32 09, 22825 Norderstedt
Gutenbergring 35, 22848 Norderstedt



Hamburg
Osnabrück
Rendsburg
IBH

Elektronik (0 40) 52 30 52 21-22
Elektromechanik (0 40) 52 30 52 26
Zentrale (0 40) 52 30 52-0
Telefax (0 40) 52 88 21 63
e-Mail info@IBH-Elektrotechnik.de



Industrial Counting and Control Components

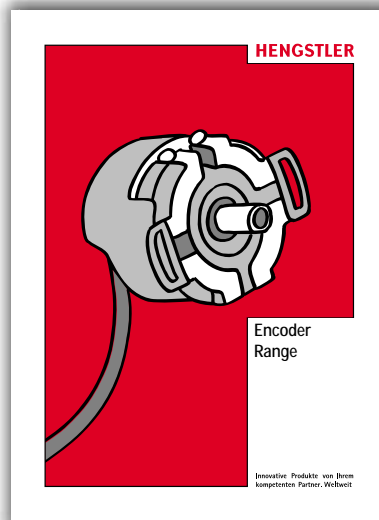

Encoders

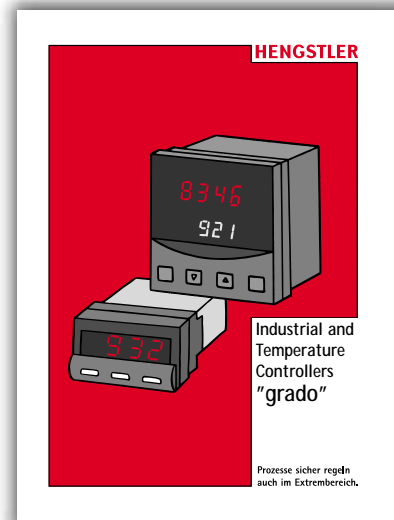

Industrial and Temperature Controllers "grado"



Program Overview Safety Relays

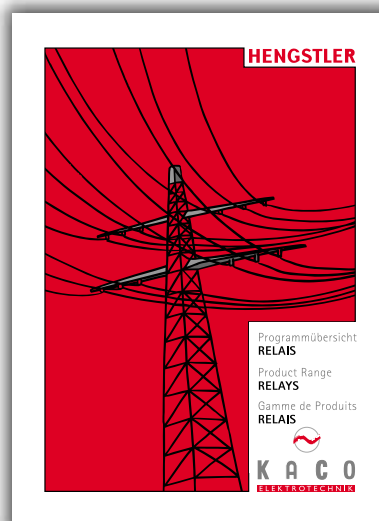

Program Overview Relays

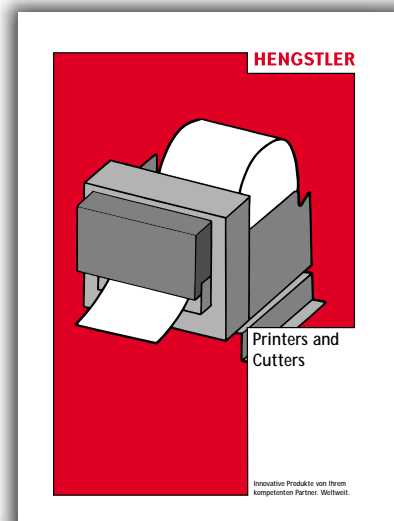

Printers and Cutters

Industrial Counting and Control Technology
The comprehensive and successful program: From mini-counters to sophisticated control counters, multi-function counters, position Indicators, tachometers, timers.

Incremental and Absolute Encoders
Technology and flexibility are highlights: Monolithic integrated OptoAsics reliably replace up to 200 SMD components. Due to the modular system customers can choose among more than 1 million variants.

Industrial and Temperature Controllers
Even in extreme situations this family of industrial and temperature controllers shows its quality. Our controllers are distinguished by very easy operation, state-of-the-art technology, safety though self-tuning and compact DIN dimensions.

Relay Technology
Safety relays, polarised bistable relays up to 30 A, PCB relays, retentive relays, industrial relays as well as high-voltage relays and mains isolation relays – a range that leaves nothing to be desired.

Data Printers and Cutters
Innovative solutions for printers and cutters is another of our strengths. All components used are highly reliable, maintenance-free and very easy to handle, including paper and ribbons. Our thermal and impact printers are used as bon or journal printers, e.g. in ATMs, kiosk systems or vending machines of all types. Powerful cutters for various cutting widths guarantee clean cuts in the most varied applications, even in extreme climatic conditions.

HENGSTLER INTERNATIONAL

■ GERMANY

Hengstler GmbH
Postfach 1151
78550 Aldingen
Tel. +49 (0) 74 24-890
Fax +49 (0) 74 24/8 94 70
<http://www.hengstler.de>
E-mail: info@hengstler.de

■ HENGSTLER GMBH

Geschäftsbereich Bauelemente
Postfach 1249
78561 Wehingen
Tel. +49 (0) 74 26-6 80
Fax +49 (0) 74 26/6 82 81
<http://www.hengstler.de>
E-mail: info.relay@hengstler.de

■ FRANCE

Hengstler Contrôle Numérique
S.A.R.L.
Z.I. des Mardelles
94-106, Rue Blaise Pascal, B.P. 71
93602 Aulnay-sous-Bois, Cédex
Tel. (01) 48795501
Fax (01) 48795561

■ GREAT BRITAIN

West Instruments
The Hyde
Brighton, East Sussex
BN2 4JU, England
Tel. +44 (0) 1273 606271
Fax +44 (0) 1273 609990

■ BRASIL

Veeder Root do Brasil
Com. e. Ind. Ltda.
Sao Paulo
CEP 05037
Tel. 5511 861-2155
Fax 5511 861-1082
e-mail: dlassner@veeder.com
e-mail: Antonio_Araujo@veeder.com

■ ITALY

Hengstler Italia S.r.l.
Via G. Cavalcanti, 5
20127 Milano MI
Tel. +39 (02) 2682-1943
Fax +39 (02) 2682-1953
E-mail: info@hengstler-italia.com

■ JAPAN

Hengstler Japan Corp. Tokyo
1-8-5, Asagayaminami
Suginami-Ku
Tokyo 166-0004
Tel. (03) 53060150
Fax (03) 53060160

■ JAPAN

Hengstler Japan Corp. Osaka
2-12-23, Minamikaneden Osaka
Suita-shi
Osaka 564-0044
Tel. (06) 63868001
Fax (06) 63865022
E-mail: mailmaster@hengstler.co.jp
<http://www.hengstler.co.jp>

■ SPAIN

Hengstler España S.A.
C/Córcega, 541, 2º 1a
08025 Barcelona
Tel. +34-93 435.51.50 / 64.28 / 76.92
Fax +34-93 347.92.60
E-mail: hengstler@hengstler.es

■ USA

Danaher Controls
1675 Delaney Road
Gurnee, IL 60031-1282
Tel. (847) 662.2666
Fax (847) 662.6633
e-mail: dancon@dancon.com
<http://www.dancon.com>

AGENTS

Argentina, Australia, Austria, Belgium, Bulgaria, Brazil, Chile, China, Colombia, Czech Republic, Denmark, Egypt, Finland, Great Britain, Greece, Guatemala, Hong Kong, Hungary, India, Indonesia, Iran, Ireland, Israel, Kenya, Korea, Lebanon, Luxemburg, Malaysia, Mexico, Netherlands, New Zealand, Norway, Pakistan, Peru, Philippines, Poland, Portugal, Romania, Singapore, Slovenia, Slovak Republic, South Africa, Spain, Sweden, Switzerland, Taiwan, Thailand, Turkey, United Arab Emirates, USA, Venezuela

HENGSTLER

Hengstler GmbH
Postfach 11 51
D-78550 Aldingen/Germany
House address: Uhlandstraße 49
D-78554 Aldingen
Tel. +49 74 24-89 0
Fax +49 74 24-89 500
<http://www.hengstler.de>
E-mail: info@hengstler.de



DQS-certified to DIN EN ISO 9001
Reg. No. 1540-01



Member of **DANAHER CORPORATION** U.S.A.

IBH ELEKTROTECHNIK GMBH Postfach 32 09, 22825 Norderstedt Gutenbergring 35, 22848 Norderstedt		IBH ELEKTROTECHNIK GMBH
Hamburg	Elektronik	(0 40) 52 30 52 21-22
Osnabrück	Elektromechanik	(0 40) 52 30 52 26
Rendsburg	Zentrale	(0 40) 52 30 52-0
IBH	Telefax	(0 40) 52 88 21 63
	e-Mail	info@IBH-Elektrotechnik.de

www.hengstler.de

All details are only intended as descriptive text and do not represent any binding assurances relating to the features described. We reserve the right to make modifications.

DOC 1005.09

Components · 2000 · 12/2000 · Printed on environmentally friendly paper from chlorine and acid-free production.

DZSW